

# CP-UNC-TB21ZL6S-VMDS-V2

2MP Full HD WDR IR Network Bullet Camera - 60Mtr.

- 1/2.8" 2MP Progressive Scan CMOS (0.9071 centimeters)
- Max. 25/30fps@2MP (1920×1080)
- Supports Starlight Function
- Instastream and H.264+ Dual-stream encoding
- WDR(120dB), Day/Night (ICR), 3D-DNR, ROI, AWB, AGC, BLC, HLC
- 2.7mm~13.5mm Motorized Lens
- IR Range of 60 Mtrs, IP67, IK10(Optional), Micro SD Card, PoE
- Mobile Software: iCMOB, gCMOB
- CMS Software: KVMS Pro



## System Overview

This Series has gathered a lot of fame over the years for its eminent capabilities on top of its artful appearance which lets it mix in any background. This series entails a wide range of easily-mountable solutions that have been crafted with the IR Megapixel technology that delivers resolutions varying from 2MP to 8MP depending on your choice of products. CP Plus 2MP Series comes with a varifocal lens/motorized/ fixed lens and is absolutely pocket-friendly, which makes it the best choice for a number of small and mid-size places.

## Starlight Technology

This camera is widely used to provide sharper and clearer picture quality with the help of its exceptional starlight sensitivity as the camera improves night vision in low light conditions. This technology is useful in conditions with extremely low light as the starlight technology turns almost completely dark images into those of clear colors.



# CP-UNC-TB21ZL6S-VMDS-V2

## 2MP Full HD WDR IR Network Bullet Camera - 60Mtr.

### Functions

#### Wide Dynamic Range (WDR)

When a scene is partly dark and partly bright, that is the dynamic range that distorts images due to this difference in the lighting. WDR technology provides you balanced lighting for a clear and vivid image throughout the day. WDR technology can be installed at entry/exit points of any building structure, jewelry shops, outdoor location among so many other places.

#### Live Viewing

Unlike some, this technology enables you to record the picture feed but view it live as well at your convenience. On top of that, the advantages of high-resolution video recording are numerous.

#### Smart Analytical Support

Using an advanced algorithm, smart analytical technology lets you set a multitude of safety parameters and sends you alerts when any of those parameters have been compromised. Not just when there's an occurrence of tripwire or intrusion.

#### True Day/Night

When the scene is too dark, the image is captured by illuminating an infrared light through the camera onto the scene that greatly helps with making the scene visible for the lens. It delivers color images during the day and automatically switches to the monochrome feature as the scene darkens.

#### Instastream

This camera has been designed with the latest and most efficient innovation among the standard video compression designs. Smart encoding algorithms developed by CP PLUS help in saving up to 70% more bandwidth than H.265 along with making it more beneficial for minimizing bandwidth and storage costs. It enhances video coding efficiency while providing high resolution and the rate of frame in the video using Intelligent Region Perception to detect motion in each frame.

#### gCMOB/ iCMOB

Designed to allow users to access and control live streaming from CP PLUS IP Cameras, DVRs/ NVRs and Video Door Phones, the CP PLUS gCMOB/ iCMOB application offers a host of features such as Easy GUI, up to 16 live viewing split-ups; InstaOn cloud support; Playback; digital zoom ins; two-way talk, and more.

### About CP PLUS

The brand that is on its way to lead the world when it comes to the security and surveillance industry, CP PLUS, keeps bombarding the market with the most reliable range of products that have been designed carefully and methodically to automate the whole surveillance and security process, no matter how big your premises are.

It was the initiative to help the public in the area where they are the most vulnerable and to empower the sense of safety in our hearts that had conceptualized CP PLUS. And embarking on its mission to make the world a safer and more secure place has taken the brand's journey to unprecedented levels even when compared to international competitors.



# CP-UNC-TB21ZL6S-VMDS-V2

## 2MP Full HD WDR IR Network Bullet Camera - 60Mtr.

Feature	Specification
Image Sensor	1/2.8" 2MP PS CMOS (0.9071 centimeters)
Minimum Illumination	0.002 Lux@F1.6 (Color, 30 IRE) 0.0002 Lux@F1.6 (B/W, 30 IRE) 0 Lux (IR on)
Effective Pixels	1920(H) x 1080(V)
Shutter Speed	Auto/Manual, 1/3~1/100000s
S/N Ratio	>56dB
Close Focus Distance	0.8m
White Balance	Auto/natural/street lamp/outdoor/manual/regional custom
Lens	2.7mm~13.5mm
Lens Type	Motorized
Mount Type	φ14
Max. Aperture	F1.5
Iris Control	Fixed
DORI Distance	W- 44.1m (Detect) 17.7m (Observe) 8.8m (Recognize) 4.4m (Identify) T- 144.8m (Detect) 57.9m (Observe) 29.0m (Recognize) 14.5m (Identify)
Noise Reduction	3D-NR
Gain Control (AGC)	Auto/Manual
Video Compression	H.265; H.264+; H.264; H.264B; MJPEG
Encode Strategy	Instastream
Angle of View	Horizontal: 108°-30° Vertical: 56°-17° Diagonal: 131°-35°
Back Light Compensation	BLC / HLC / WDR(120dB)
Video Streaming	Main stream: 1920 × 1080@1-25/30 fps Sub stream: 704 × 576@1-25 fps 704 × 480@1-30 fps *The values above are the max. frame rates of each stream; for multiple streams, the values will be subjected to the total encoding capacity.
Resolution	2MP(1920 × 1080); 1.3MP(1280 × 960); 720P (1280 × 720); D1(704 × 576/704 × 480); VGA (640 × 480); CIF(352 × 288/352 × 240)

Feature	Specification
Motion detection	Off/ On (4 areas, rectangular)
Privacy Mask	4 areas
ICR	Auto (ICR)/Color/B/W
ROI	Yes (4 areas)
Audio Input	1 Channel (RCA port)
Audio Output	1 Channel (RCA port)
Audio Compression	G.711a; G.711Mu; G.726; AAC
Alarm IN	1 channel In: 5mA 5VDC
Alarm Out	1 channel Out: 300mA 12VDC
Video Bit Rate	H.264: 32 Kbps–6144 Kbps, H.265: 12 Kbps–6144 Kbps
Bit Rate	CBR/VBR
Protocol	IPv4; IPv6; HTTP; TCP; UDP; ARP; RTP; RTSP; RTCP; RTMP; SMTP; FTP; SFTP; DHCP; DNS; DDNS; QoS; UPnP; NTP; Multicast; ICMP; IGMP; NFS; PPPoE; Bonjour; ONVIF (Profile S/Profile G/Profile T); CGI; Milestone; InstaOn
Smart Detection	Tripwire, Intrusion
Ethernet	RJ-45 (10/100Base-T)
SDK and API	Yes
Cyber Security	Video encryption; firmware encryption; configuration encryption; Digest; WSSE; account lock-out; security logs; IP/MAC filtering; generation and importing of X.509 certification; syslog; HTTPS; 802.1x; trusted boot; trusted execution; trusted upgrade
Alarm Event	No SD card; SD card full; SD card error; network disconnection; IP conflict; illegal access; motion detection; video tampering; defocus detection; tripwire; intrusion; audio abnormality; voltage detection; external alarm; security exception
User/Host	20 (Total bandwidth: 48 M)
Mirror	Yes
Smart Phone	iPhone, iPad, Android Phone
Browser	IE, Chrome, Firefox
IR	IR Range upto 60 Mtr., Smart IR
IR LEDs Number	4

Feature	Specification
Micro SD	FTP; SFTP; Micro SD Card (support max. 256 GB); NAS
Operating Temperature	-30 °C to +60 °C (-22 °F to +140 °F) ; ≤ 95%
Storage Temperature	-40°C to +60°C (-40°F to +140°F)
Power Source	12V DC/PoE (802.3af)
Power Consumption	Basic: 1.8 W (12 V DC); 2.2 W (PoE) Max. (ICR + H.265 + max. resolution + main stream + IR intensity + WDR + IVS + vari-focal); 8.2 W (12 V DC); 9.8 W (PoE)
Weatherproof Standard	IP67, IK10(optional)
Casing	Metal
Dimension	Φ244.1 mm × 90.4 mm (Φ9.61" × 3.26")
Weight	0.89 kg

Dimensions (mm/inch)

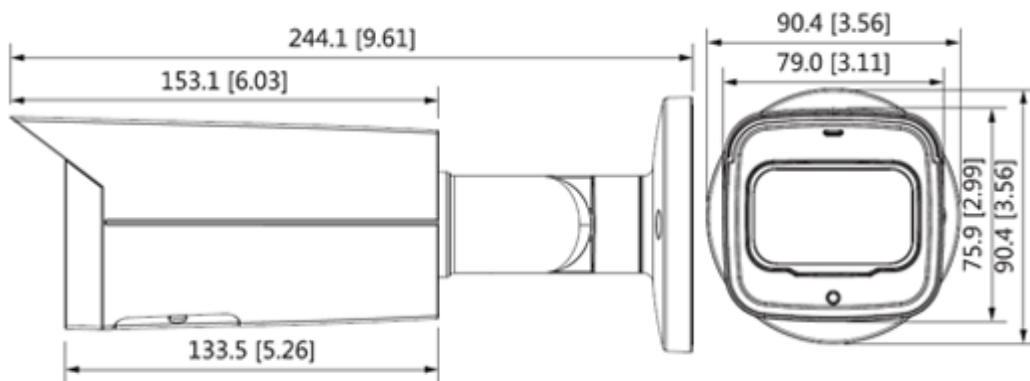

Accessories : Optional

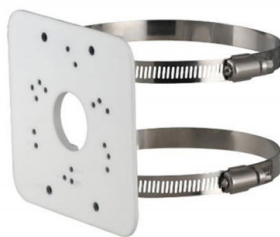

CP-UA-B2P

Pole Mount

**Company Name:**

CP PLUS (Aditya Infotech Ltd.)  
F-28 Okhla Industrial Area, Phase 1,  
New Delhi 110020, INDIA

**Contact Mail ID :-** [customer@cpplusworld.com](mailto:customer@cpplusworld.com)